

Lubrication Fittings & Accessories

Threaded Fittings



On the straight and angle fittings, the ball check end or the greasing end is heat treated. The spin-drive and drive-type angle fittings are entirely heat treated. All fittings are zinc plated and have a supplemental coating.

1/4" - 28 Thread (Straight & Taper)

This type of thread is used mostly on cars and light trucks. The SAE-LT is a thread that conforms to the Society of Automotive Engineers lubrication fittings thread specification.



No. 5010
*No. 5010-1
1/4" -28 Taper Thd.
(SAE-LT)



No. 5527
1/4" -28 U.N.F.
2A Thd.



No. 5013
1/4" -28 Taper Thd.
(SAE-LT)



No. 5014
1/4" -28 Taper Thd.
(SAE-LT)



No. 5210
1/4" -28 Taper Thd.
(SAE-LT)



No. 5410
1/4" -28 Taper Thd.
(SAE-LT)



No. 700396
1/4" -28 Taper Thd.
(SAE-LT)

Part No.	A in./mm	B in./mm	C in./mm	D in./mm	E	F in./mm	G in./mm
5527	1 ⁷ / ₃₂ / 14.0	1 ¹ / ₆₄ / 4.4	9 ³² / 7.1	.250 / 6.4	—	—	—
5010	1 ⁷ / ₃₂ / 13.5	3 ¹⁶ / 4.8	5 ¹⁶ / 7.9	.260 / 6.6	—	—	—
* 5010-1	3 ⁵ / ₆₄ / 13.9	7 ³² / 5.6	5 ¹⁶ / 7.9	.260 / 6.6	—	—	—
5013	1 ¹ / ₁₆ / 17.5	2 ³ / ₆₄ / 9.1	5 ¹⁶ / 7.9	.260 / 6.6	—	—	—
5014	1 ⁵ / ₁₆ / 23.8	3 ⁹ / ₆₄ / 15.5	5 ¹⁶ / 7.9	.260 / 6.6	—	—	—
5210	1 ³ / ₁₆ / 20.6	1 ³ / ₆₄ / 5.1	3 ⁸ / 9.5	.260 / 6.6	45°	3 ⁷ / ₆₄ / 14.7	2 ⁷ / ₆₄ / 10.7
5410	3 ⁴ / 19.1	3 ¹⁶ / 4.8	3 ⁸ / 9.5	.260 / 6.6	90°	2 ¹ / ₃₂ / 16.7	1 ⁵ / ₃₂ / 11.9
700396	2 ⁵ / ₃₂ / 19.8	1 ⁹ / ₆₄ / 7.5	3 ⁸ / 9.5	.260 / 6.6	65°	2 ¹ / ₃₂ / 16.7	1 ⁵ / ₃₂ / 11.9

* Not illustrated. Same as No. 5010 but without Ball Check.

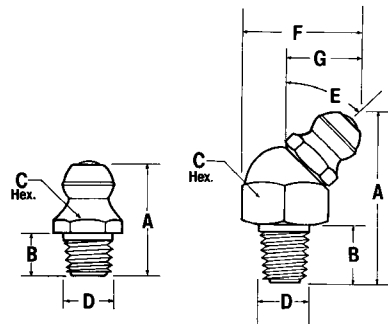

1/8" Pipe Thread

The 1/8" pipe threaded fittings are constructed for additional strength. This type of fitting is popular for use in the construction and agricultural industry and large industrial machinery.



No. 5000
1/8" P.T.F. Spec.
Extra Short



No. 5003
1/8" P.T.F.
Spec. Short



No. 5009
1/8" P.T.F.
Spec. Short



No. 5505
1/8" N.P.T.F.



No. 5200
1/8" P.T.F.
Spec. Short



No. 5300
1/8" P.T.F.
Spec. Short



No. 5308
1/8" P.T.F.
Spec. Short



No. 5400
1/8" P.T.F.
Spec. Short

Part No.	A in./mm	B in./mm	C in./mm	D in./mm	E	F in./mm	G in./mm
5000	2 1/32 / 16.7	1 9/64 / 7.5	7/16 / 11.1	.400 / 10.2	—	—	—
5003	1 1/4 / 31.8	2 5/32 / 19.8	7/16 / 11.1	.400 / 10.2	—	—	—
5009	2 5/8 / 66.7	2 5/32 / 54.8	7/16 / 11.1	.400 / 10.2	—	—	—
5505	1 / 25.4	5/16 / 7.9	1/2 / 12.7	.480 / 12.2	—	—	—
5200	5 7/64 / 22.6	1 9/64 / 7.5	7/16 / 11.1	.400 / 10.2	45°	4 1/64 / 16.3	2 7/64 / 10.7
5300	7/8 / 22.2	9/32 / 7.1	7/16 / 11.1	.400 / 10.2	65°	2 3/32 / 18.3	1/2 / 12.7
5308	1 7/32 / 31.0	9/16 / 14.3	7/16 / 11.1	.400 / 10.2	65°	2 3/32 / 18.3	1/2 / 12.7
5400	2 7/32 / 21.4	9/32 / 7.1	7/16 / 11.1	.400 / 10.2	90°	4 7/64 / 18.7	1/2 / 12.7

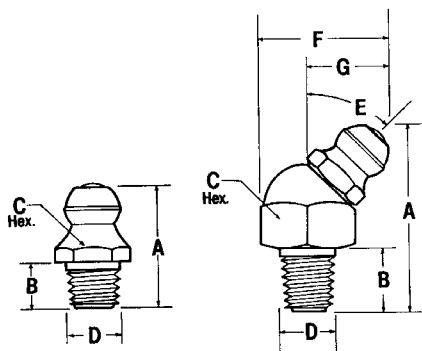



No. 5050
1/4" N.P.T.

1/4" Pipe Thread

Part No.	A in./mm	B in./mm	C in./mm	D in./mm	E in./mm	F in./mm	G in./mm
5050	53/64 / 21.0	3/8 / 9.5	9/16 / 14.3	.535 / 13.6	—	—	—
5350	1 1/32 / 26.2	3/8 / 9.5	9/16 / 14.3	.535 / 13.6	65°	13/16 / 20.6	7/32 / 13.5



No. 5350
1/4" N.P.T.F. Spec.
Extra Short

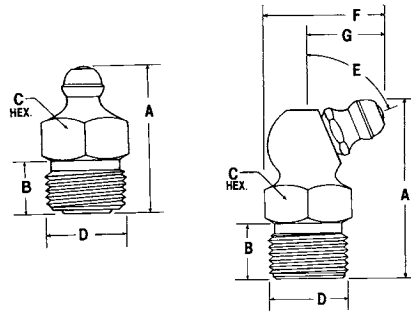

No. 5181
10 mm x 1

Metric Fittings – 6mm, 8mm, 10mm

Part No.	A in./mm	B in./mm	C mm	D mm	E	F in./mm	G in./mm
* 5175	33/64 / 13.1	13/64 / 5.2	7	6 mm x 1	—	—	—
* 5176	7/8 / 22.2	7/32 / 5.6	9		45°	37/64 / 14.7	25/64 / 9.9
* 5177	45/64 / 17.9	7/32 / 5.6	9		90°	3/4 / 19.1	9/16 / 14.3
* 5178	37/64 / 14.7	7/32 / 5.6	9	8 mm x 1	—	—	—
* 5179	7/8 / 22.2	7/32 / 5.6	9		45°	37/64 / 14.7	25/64 / 9.9
* 5180	45/64 / 17.9	7/32 / 5.6	9		90°	3/4 / 19.1	9/16 / 14.3
5181	39/64 / 15.5	7/32 / 5.6	11	10 mm x 1	—	—	—
5182	15/16 / 23.8	7/32 / 5.6	11		45°	41/64 / 16.3	27/64 / 10.7
5183	47/64 / 18.7	7/32 / 5.6	11		90°	45/64 / 17.9	1/2 / 12.7

* Not illustrated.



No. 5183
10 mm x 1

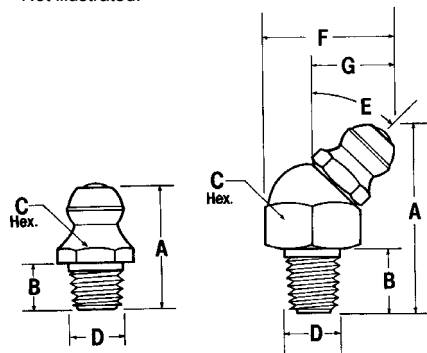

Spin-Drive

Spin-Drive (thread forming) fittings have special tapered drive threads for fast production line installation in untapped holes to save tapping cost. Spinning into the hole with a power wrench provides the most effective installation. Installation torque limits, to avoid stripping, should be established by test in the type of material in which production fittings are to be installed. Installation force causes a rearrangement of mating material to conform with the fitting thread contour creating a leak-tight permanent seal. Not recommended for heat treated parts. Fitting threads are heat treated to Rockwell 83-89 on the 15N scale.

For field servicing, Spin-Drive fittings may be replaced by any standard fitting having the same thread size or another Spin-Drive fitting.



No. 205010
1/4"-28 Spec. Taper Drive Th'd.



No. 205000
1/8" Pipe-Special Taper Drive Th'd.



No. 247235
1/8" Pipe-Special Taper Drive Th'd.



No. 205210
1/4" -28 Spec. Taper Drive Th'd.



No. 205200
1/8" Pipe-Special Taper Drive Th'd.



No. 205410
1/4" -28 Spec. Taper Drive Th'd.



No. 205400
1/8" Pipe-Special Taper Drive Th'd.

Spin-Drive Fittings

Part No.	A in./mm	B in./mm	C in./mm	D in./mm	E	F in./mm	G in./mm
205010	9/16 / 14.3	3/16 / 4.8	5/16 / 7.9	.256 / 6.5	—	—	—
205000	5/8 / 15.9	1/4 / 6.4	7/16 / 11.1	.396 / 10.1	—	—	—
247235	45/64 / 17.9	21/64 / 8.3	7/16 / 11.1	.400 / 10.2	—	—	—
205210	13/16 / 20.6	13/64 / 5.1	3/8 / 9.5	.256 / 6.5	45°	37/64 / 14.7	3/8 / 9.7
205200	21/32 / 21.4	13/64 / 5.2	7/16 / 11.1	.396 / 10.1	45°	21/32 / 16.7	27/64 / 10.7
205410	3/4 / 19.1	3/16 / 4.8	3/8 / 9.5	.256 / 6.5	90°	21/32 / 16.7	15/32 / 11.9
205400	49/64 / 19.3	13/64 / 5.2	7/16 / 11.1	.396 / 10.1	90°	47/64 / 18.7	33/64 / 13.0

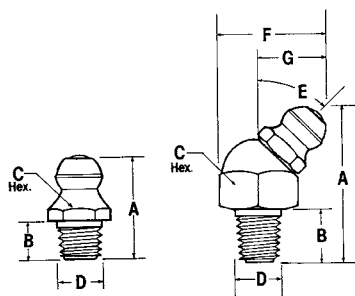

Drive-Type Fittings

Drive-type fittings are designed for fast production line installation in untapped holes to save thread tapping costs. Circumferential serrations on shank provide a hydraulic tight seal when fitting is installed properly. Cannot be used where high lubricant back pressures can be developed.

Hole sizes and shank dimensions are for reference use only. To determine optimum hole size, test applications should be conducted using the type of material into which the fitting is to be installed—steel, cast iron, brass, aluminum, etc. Production tolerances of hole size must be taken into consideration when test is conducted.

Drive-Type Fittings



No. 5033
For 3/16" / 4.8 mm
Dia. Hole



No. 5031
For 3/16" / 7.9 mm
Dia. Hole



No. 5036
For 3/16" / 9.5 mm
Dia. Hole



No. 5385
For 3/16" / 4.8 mm
Dia. Hole



No. 5318
For 1/4" / 6.4 mm
Dia. Hole



No. 700504
For 3/16" / 4.8 mm
Dia. Hole

Part No.	A in./mm	B in./mm	C in./mm	D in./mm	E	F in./mm	G in./mm
5033	33/64 / 13.1	15/64 / 6.0	5/16 / 7.9	.196 / 5.0	—	—	—
5031	35/64 / 13.9	1/4 / 6.4	3/8 / 9.5	.322 / 8.2	—	—	—
5036	5/8 / 15.9	1/4 / 6.4	7/16 / 11.1	.383 / 9.7	—	—	—
5385	23/32 / 18.3	7/32 / 5.6	3/8 / 9.5	.196 / 5.0	65°	1 1/16 / 17.5	1/2 / 12.7
5318	49/64 / 19.4	9/32 / 7.1	3/8 / 9.5	.259 / 6.6	65°	1 1/16 / 17.5	1/2 / 12.7
700504	1/2 / 12.7	3/16 / 4.8	5/16 / 7.9	.196 / 5.0	—	—	—

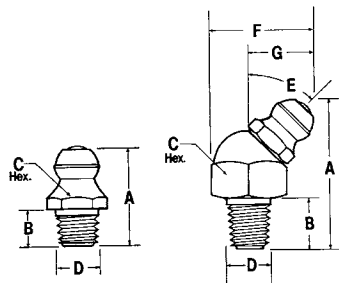

No. 700502
For 1/4" / 6.4 mm
Dia. Hole

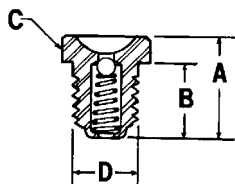

Flush Type Fittings

For use where installation of protruding fitting cannot be used. Can be used on shafts, pulleys, or other type of rotating bearing or parts.

Part No.	A in./mm	B in./mm	C in./mm	D in. / mm
700502	3/32 / 7.1	15/64 / 6.0	5/16 / 7.9 Dia.	.256 / 6.5

Stainless Steel Fittings

Select Lincoln stainless steel fittings for marine applications, food processing machinery, sewage disposal systems or any use where protection against corrosive elements is a design criteria. Stainless steel ball checks and springs are securely housed in passivated austenitic type 303 stainless steel bodies for maximum usable life and performance. To avoid use of inferior substitutes specify Lincoln Stainless Steel fittings by part number on your drawings.



No. 5010-9
1/4" -28 Taper Thd.
(SAE-LT)



No. 5000-9
1/8" P.T.F. Spec. Extra
Short



No. 5410-9
1/4" -28 Taper Thd.
(SAE-LT)



No. 5033-9
For 3/16"/4.8 mm
Dia. Hole

Stainless Steel Fittings

Part No.	A in./mm	B in./mm	C in./mm	D in./mm	E	F in./mm	G in./mm
5010-9	1 ¹ / ₃₂ / 13.5	3 ¹ / ₁₆ / 4.8	5 ¹ / ₁₆ / 7.9 Hex.	.260 / 6.6	—	—	—
5000-9	4 ¹ / ₆₄ / 16.3	9 ¹ / ₃₂ / 7.1	7 ¹ / ₁₆ / 11.1 Hex.	.400 / 10.2	—	—	—
5410-9	3 ¹ / ₄ / 19.1	3 ¹ / ₁₆ / 4.8	3 ¹ / ₈ / 9.5 Hex.	.260 / 6.6	90°	2 ¹ / ₃₂ / 16.7	1 ¹ / ₃₂ / 11.9
5033-9	9 ¹ / ₁₆ / 14.3	1 ¹ / ₄ / 6.4	5 ¹ / ₁₆ / 7.9 Dia.	.196 / 5.0	—	—	—

Max. 600°F (315°C)

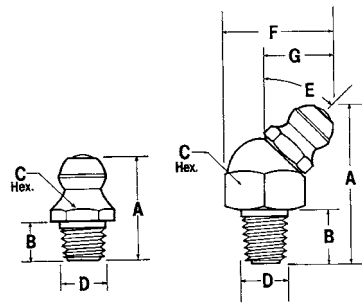

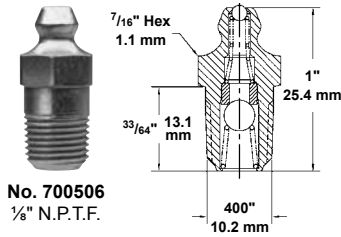

No. 700506
1/8" N.P.T.F.

Leakproof Fitting

Leakproof fittings are special purpose fittings for use in those applications where a positive seal is essential. A special steel ball check, brass insert seat and a surface ball check provide an effective seal. Designed for grease, medium and heavy oils, it withstands a back pressure up to 10,000 psi (690 bar).

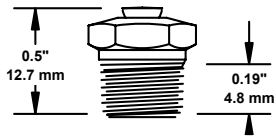

No. 5677
1/8" P.T.F. Spec. Short

Pressure Relief Valves

Use wherever control of oil or grease pressure is required. Releases pressure build up during equipment operation or when filling gear cases or bearing housings with pressure guns. Twin vent ports provide visual indication of pressure relief. Select valve with pressure range best suited to design application.

Part	Relief Pressure
5677	1 to 5 psig / .07 to .34 bars
5678	7½ to 15 psig / .52 to 1 bars
5679	15 to 25 psig / 1 to 1.7 bars
5680	45 to 80 psig / 3.1 to 5.5 bars

Operating parts are positioned internally for maximum protection against entry of dirt or valve damage. Ball check is located at base of valve body as close as possible to protected material. Not recommended to be used below the fluid level.

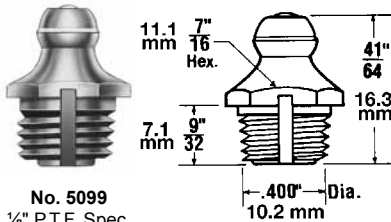

No. 5099
1/8" P.T.F. Spec. Extra Short

Safety Vent Fitting

Required for use in those applications where a build up of pressure in the bearing is undesirable or damaging. A vent slot cut vertical to the threads provides an air escape during bearing fill and when grease appears serves as a bearing fill indicator. Vent slot restriction permits bearing fill without build up of prohibitive pressure.

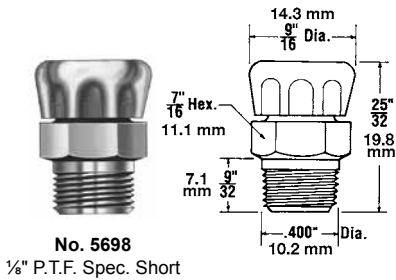

No. 5698
1/8" P.T.F. Spec. Short

Atmospheric Vent

For use on differentials, transmissions and gear boxes. It allows air to escape and enter as the internal pressure increases or decreases. The cap prevents dirt from entering. Must be installed above the normal level of fluid.

Button Head Fittings

Lincoln standard button head fittings (5/8" diameter head) are designed for use where volume flow of lubricant is required, such as bearings on earth moving equipment, conveyors and mining machinery. Heat treated and zinc plated for long service life.



No. 5701
1/4" N.P.T.F.



No. 5706
1/4" N.P.T.F.



No. 5711
3/8" N.P.T.F.

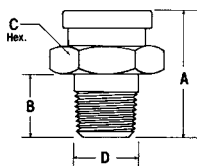

Part No.	A in./mm	B in./mm	C in./mm	D in./mm
5701	3/4 / 19.1	23/64 / 9.1	5/8 / 15.9	.405 / 10.3
5706	27/32 / 21.4	7/16 / 11.1	5/8 / 15.9	.540 / 13.7
5711	1 1/16 / 27.0	37/64 / 14.7	3/4 / 19.1	.675 / 17.1

Button head coupler needed: 81458
Adapter: 10460
Gasket: 31138

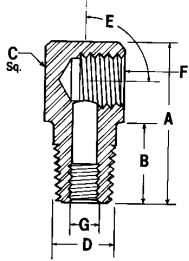

Street Elbows

Part No.	Style	A in./mm	B in./mm	C in./mm	D in./mm	E	F	G in./mm
20026	1	1 ³ / ₁₆ / 20.6	5 ¹ / ₁₆ / 7.9	1/2 / 12.7 Sq.	1/4-28 Taper	90°	1/8 PTF	—
247616	2	1 ¹ / ₁₆ / 27	1 ⁷ / ₃₂ / 13.5	1/2 / 12.7 Sq.	1/4-28 Taper	45°	1/8 PTF	—
20028	2	1 / 25.4	1 ⁵ / ₃₂ / 11.9	1/2 / 12.7 Sq.	1/8 PTF	45°	1/8 PTF	—
20031	1	1 ³ / ₁₆ / 20.6	9 ³ / ₃₂ / 7.1	1/2 / 12.7 Sq.	1/8 PTF	90°	1/8 PTF	—
20029	1	1 / 25.4	1 ⁵ / ₃₂ / 11.9	1/2 / 12.7 Sq.	1/8 PTF	90°	1/8 PTF	—
13155	2	1 / 25.4	3/8 / 9.5	1/2 / 12.7 Sq.	1/8 NPSM	90°	1/8 NPTF	1/4-28 UNF
13129	1	1 1/2 / 38.1	7/8 / 22.2	5/8 / 5.9 Sq.	1/8 NPTF	90°	1/8 NPTF	—

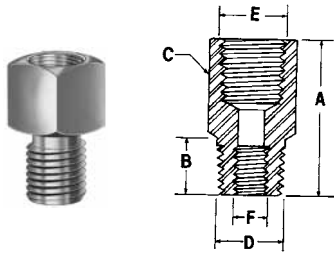

Adapters

Part No.	A in./mm	B in./mm	C in./mm	D	E	F
20024	7/8 / 22.2	5/16 / 7.9	1/2 / 12.7 Hex.	1/2" / 12.7 mm	1/8 NPSF	—
10182	1 ⁵ / ₁₆ / 23.8	3/8 / 9.5	9/16 / 14.3 Hex.	1/8 NPTF	1/8 NPTF	—
13154	7/8 / 22.2	3/8 / 9.5	1/2 / 12.7 Sq.	3/16" / 4.8 mm	1/8 NPTF	1/4-28 UNF
14054	7/8 / 22.2	7/16 / 11.1	1/2 / 12.7 Sq.	1/4" / 6.4 mm	1/8 NPTF	1/4-28 UNF

Plugs



No. 12511
1/8" P.T.F. Spec. Extra Short

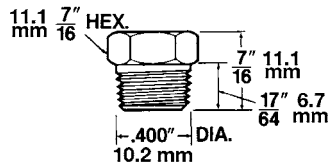

No. 700337
1/4"-28 Spec. Taper Drive Th'd.

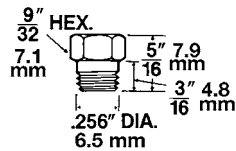



Fitting Installation and Removal Tools

Model 11485

For use to install straight drive-type fittings into untapped holes.



Model 11509

For use to install angle drive-type fittings into untapped holes.



Easy Out Tool

Combination tool for removing worn or broken fittings and retapping holes for new fitting installation, two models available:

Model G904

For tapping $\frac{1}{4}$ " -28 threads and removal of both $\frac{3}{8}$ " and $\frac{5}{16}$ " Hex, straight or angle fittings.

Model G905

For tapping $\frac{1}{8}$ " NPT threads and removal of both $\frac{7}{16}$ " Hex, straight or angle fittings.

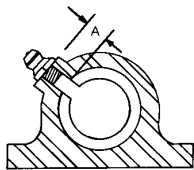

Depth of Engagement

When selecting a lubrication fitting, either straight, angle, standard thread, spin-drive or straight drive, be sure to measure engagement depth "A," taking manufacturing tolerance into consideration. Then select fitting with thread length or drive shank length that will not penetrate bearing material or rest against rotating member.

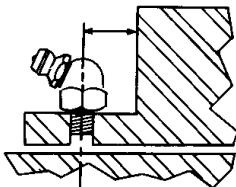

Turning Radius

The turning radius is given for all angle fittings shown in this manual. Be sure that this is taken into consideration during initial machine design and then select a fitting with a turning radius that will permit easy production line installation.

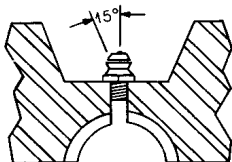

Deep Set Fittings

Deep set fittings are sometimes necessary in machine design. When required, make sure sufficient clearance is provided for easy disengagement of hydraulic coupler.

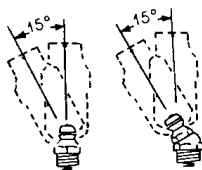

Angularity of Contact

Lincoln hydraulic couplers and fittings are designed to provide a hydraulic seal at any coupler angle up to 15° . Movement beyond this angle will cause coupler to disengage.

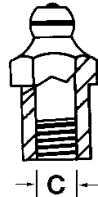
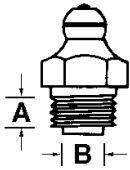

Determination of Pipe Thread Sizes

Nominal Pipe Thread Size	Threads Per Inch	Major Dia. B or C in. / mm	Nominal Engagement for tight Joint A in. / mm
1/8"	27	.405 / 10.3	1/4 / 6.4
1/4"	18	.540 / 13.7	3/8 / 9.5
3/8"	18	.675 / 17.1	3/8 / 9.5
1/2"	14	.840 / 21.3	1/2 / 12.7
3/4"	14	1.050 / 26.7	5/16 / 14.3
1"	11 1/2	1.315 / 33.4	11/16 / 17.5

Drill Size Selection

Fitting Thread Size	Tap Drill Selection for Standard Thread Fitting	Drilling Size Selection for Spin-Drive Fittings
1/4" -28	#3 (for soft metal, use #5)	"A" - .234" / 5.9mm Dia. *
5/16" -32	5/32" / 7.1mm (for soft metal, use "J")	-
1/8" Pipe	11/32" / 8.7mm (for soft metal, use "R")	3/8" - .375" / 9.5mm Dia. *
1/4" Pipe	7/16" / 11.1mm	-

* Drill sizes given are nominal and may vary with different types of material. For maximum effectiveness, test applications should be conducted using the type of material into which the fitting is to be installed (steel, cast iron, brass, aluminum, etc.). Production tolerances of hole must be taken into consideration when conducting test.

Lubrication Fitting Thread Symbols

The identification symbols and their meaning which have been adopted for the various threads used in the manufacture of lubrication fittings are given below:

Symbol	Meaning
NPT	American Standard Taper Pipe Thread
NPTF	Dryseal American Standard Taper Pipe Thread
PTF	Same as NPTF except full thread length has been shortened by one thread on small end of thread—also designated as PTF—SAE Short
PTF Special Short	Same as PTF Short except one full thread has been shortened from large end of thread
PTF Special Extra Short	Same as PTF Short except two full threads have been shortened from large end of thread
NPSF	Dryseal American Fuel Internal Straight Pipe Thread
NPSI	Dryseal American Intermediate Internal Straight Pipe Thread
NPSM	American Standard Straight Mechanical Pipe Thread
1/4" -28 Taper Thread (SAE-LT)	Thread has a 3/4" taper per foot and a pitch diameter of .2257/.2224 at small end. The mating tapped hole is 1/4" -28 UNF 3B straight thread. Tap drill must not exceed .215" diameter.
1/4" -28 Special Taper Drive Thread	Thread Forming-Forms thread in mating part during installation—when removed can be replaced by standard 1/4" -28 taper thread (SAE-LT) fitting.
1/8" Pipe Special Taper Drive Thread	Thread Forming-Forms thread in mating part during installation—when removed can be replaced by standard 1/8" -27 PTF series fitting.

Symbol	Designation	Symbol	Designation
N	American Standard	S	Straight
P	Pipe	M	Mechanical
T	Taper	I	Intermediate
F	Fuel	LT	Lubrication Thread

Lubrication Fittings & Accessories

Remote Lube Fitting Systems



Hard-to-reach lubrication fittings present a major maintenance problem for the proper care of all types of machinery. Hidden or guarded lubrication fittings can mean production downtime, higher operating and maintenance costs and risk of personal injury to operators and employees—all directly traceable to poor lubrication fitting access. How do you eliminate these problems? Lincoln's Remote Lube Fitting Systems benefit you by providing easy access to lubrication fittings; lubrication is easier, quicker and safer; assures all bearings will be lubricated—and can be safely lubricated while machine is operating; and finally, it's possible to reach hidden, inaccessible or hazardous bearings.



Junction Blocks

Junction block surface mount systems are used to bring multiple lubrication points to a common, easily accessible location. The junction blocks provide a means for coupling lubricant feed lines to bearings with lubrication fittings. They are available in three basic design groups and may be mounted in multiple units to meet all application requirements.

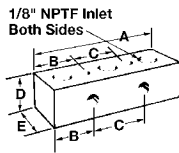

No. 13147

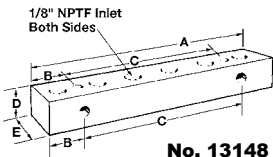

No. 13148

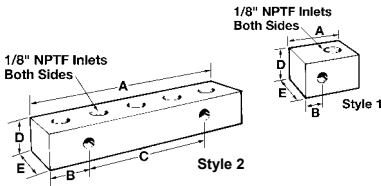

Style 1

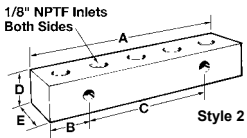

Style 2

Group I

Have $1\frac{1}{32}$ " diameter mounting holes at 90° intervals, for use with $\frac{5}{16}$ " diameter mounting bolts. This permits horizontal or vertical positioning of lubricant inlet passages.

Part No.	No. of Inlets	A in./mm	B in./mm	C in./mm	D in./mm	E in./mm
13147	3	2 $\frac{3}{4}$ / 69.9	$\frac{7}{8}$ / 22.2	1 / 25.4	$\frac{3}{4}$ / 19.1	$\frac{3}{4}$ / 19.1
13148	6	5 $\frac{3}{4}$ / 146.1	$\frac{7}{8}$ / 22.2	4 / 101.6	$\frac{3}{4}$ / 19.1	$\frac{3}{4}$ / 19.1

Group II

Have $\frac{9}{32}$ " diameter mounting holes for use with $\frac{1}{4}$ " diameter mounting bolts. Mounting holes are perpendicular to inlet passages permitting vertical positioning only.

Group II without Fitting Part No.	Style	No. of Inlets	A in./mm	B in./mm	C in./mm	D in./mm	E in./mm
14570	1	1	1 $\frac{1}{4}$ / 31.8	$\frac{3}{8}$ / 9.5	—	$\frac{3}{4}$ / 19.1	$\frac{3}{4}$ / 19.1
14562	1	2	1 $\frac{3}{4}$ / 44.5	$\frac{7}{8}$ / 22.2	—	$\frac{3}{4}$ / 19.1	$\frac{3}{4}$ / 19.1
14771	2	3	2 $\frac{3}{4}$ / 69.9	$\frac{7}{8}$ / 22.2	1 / 25.4	$\frac{3}{4}$ / 19.1	$\frac{3}{4}$ / 19.1
14563	2	4	3 $\frac{3}{4}$ / 95.3	$\frac{7}{8}$ / 22.2	2 / 50.8	$\frac{3}{4}$ / 19.1	$\frac{3}{4}$ / 19.1
14564	2	5	4 $\frac{3}{4}$ / 120.7	$\frac{7}{8}$ / 22.2	3 / 76.2	$\frac{3}{4}$ / 19.1	$\frac{3}{4}$ / 19.1
14772	2	6	5 $\frac{3}{4}$ / 146.1	$\frac{7}{8}$ / 22.2	4 / 101.6	$\frac{3}{4}$ / 19.1	$\frac{3}{4}$ / 19.1



Mounting Bolts and Nuts

Part No.	A in./mm	B in./mm	C in./mm
50057	¼"-20	1½ / 38.1	¾ / 19.1

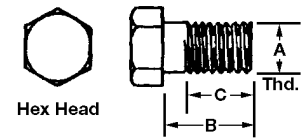

Part No.	A in./mm	B in./mm	C in./mm
51304	¼"-20	⅞ / 5.6	⅞ / 11.1
51026	⅝"-18	1⅞ / 6.7	½ / 12.7

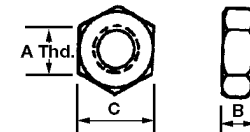

Accessories

Supply and Feed Line Hose ⅛" ID



Part No.	Alvania #2 Grade Grease Filled Coils	Minimum Burst	Max. Working Pressure	Minimum Bending	Hose Construction
241286	26 ft. / 7.9 M	10,000 psig 690 bar	4,000 psig 276 bar	3½" 88.9 mm	Nylon Tube, Dacron Braid, Polyurethane Cvr
241287	35 ft. / 10.7 M				
241288	40 ft. / 12.2 M				
252717	200 ft. / 61 M non grease filled				

Note: Use with hose ends No. 241289 or No. 246002. Temperature range: -40° F to 212° F.

Feed Line Nylon Tubing



Part No.	Description	O.D.	Wall Thickness	Burst Pressure	Working Pressure	Minimum Bending Radius	Working Temp.
247022	500 ft./152.4 M coil non-grease filled	¼" 6.4 mm	.050" 1.3 mm	2500 psig 172 bar	625 psig 42.5 bar	.875 / 22.2	-65°F to +150°F -54°C to +65°C
242025	25 ft. / 7.6 M coil grease filled						
242050	50 ft. / 15.2 M coil grease filled						
62357	100 ft./30.5 M coil non-grease filled						
274047	25 ft. / 7.6 M coil grease filled		.062" 1.6 mm	2000 psig 138 bar	500 psig 34.5 bar	0.5 / 12.7	-65°F to +200°F -54°C to +93°C
274048	50 ft. / 15.2 M coil grease filled						
274049	100 ft./30.5 M coil non-grease filled						
274050	500 ft./152.4 M coil non-grease filled						

Steel Tubing



Part No.	Description	Max. Working Pressure
62175	⅛" OD x .020" wall 25' coil 3.2mm OD x .5mm wall 7.6m coil	4400 psig 300 bar
62176	¼" OD x .028" wall 25' coil 6.4 mm OD x .7mm wall 7.6m coil	2800 psig 190 bar

Installation Tools



Plastic Tube & Hose Cutter
Part No. 226-12508-5
 Replacement Blade
Part No. 226-13095-7



Hose Ends for 1/8" I.D. Hose

Part No.	Description
241289	1/8" NPT swedge on hose stud (Requires swedging tool)
246002	1/8" NPT field installable hose coupling (swedging tool not required)

Installation Tools



Hose Swedging Tool
Part No. 241238

Hose Ends for Use with Quickline Fittings

Part No.	Description
272394	Hose stud, 90° (to be used with 272427)
272401	Hose stud, straight (to be used with 272427)
272427	Threaded sleeve
274238	Stainless steel hose stud sleeve
274239	Stainless steel straight hose

Hose End Connecting Tools

Part No.	Description
274062	Hand vise for quick connect and reusable hose ends

Bulkhead Connectors

Part No.	Style	A	B	C	D
13154	1	1/8" PTF	1/2" / 12.7 mm	1/4" -28	3/16" / 4.8 mm
14054	1	1/8" PTF	1/2" / 12.7 mm	1/4" -28	1/4" / 6.4 mm
13155	2	1/8" PTF	1/2" / 12.7 mm	1/4" -28	3/16" / 4.8 mm
51055	Lock Nut 1/8" N.P.S.M. thread				

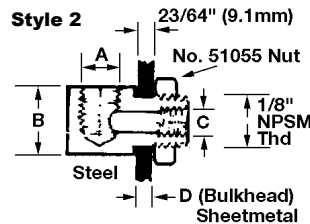
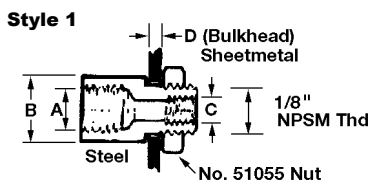
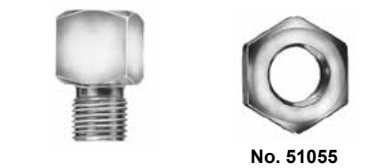

Adapter Union

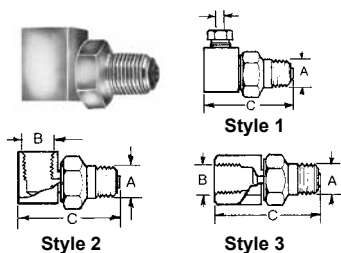

Reducing Bushings

Part No.	A	B	C	D
20024	1/4" -28 THD	1/8" NPSF	7/8" / 22.2mm	1/2" / 12.7 mm
67132	3/8" NPT	1/8" NPT	3/4" / 19.1mm	1 1/16" / 17.5mm Hex
20011	3/8" NPT	1/4" NPT	3/4" / 19.1mm	3/4" / 19.1mm Hex
273482	8 mm x 1.0	1/8" NPT	0.96" / 24.4mm	9/16" / 14.2mm

Swivels

Part No.	Style	A	B	C
66717	1	1/8" NPT	—	1 1/4" / 31.8mm
91048	2	1/8" NPT	1/8" NPT	1 1/4" / 31.8mm
91308	3	1/8" NPT	1/8" NPT	1 3/8" / 34.9mm

Note: Not suitable for installations requiring continuous rotation.

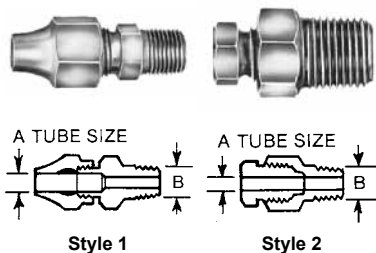

Tube Connectors

Part No.	Style	A	B	Type
66200	1	¼" O.D.	⅛" NPT	STGT
66201	1	¼" O.D.	⅛" NPT	90°
66414	2	⅛" O.D.	⅛" NPT	90°
66415	2	⅛" O.D.	⅛" NPT	STGT
66714	2	⅛" O.D.	¼"-28 thd.	STGT
66716	2	⅛" O.D.	¼"-28 thd.	90°



Compression Nut

No. 66260 for use with Style 2 Tube Connectors and 66717 Swivel.
For ⅛" O.D. Tubing. Thread size is ⅝"-24.



Sleeve

No. 68462 for use with Style 1 Tube Connectors. For ¼" O.D. Tubing.



Nut

No. 68464 for use with Style 1 Tube Connectors. For ¼" O.D. Tubing.

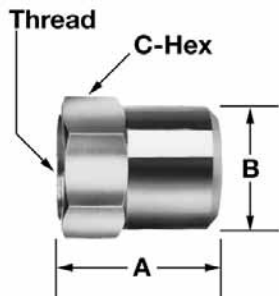

Zerk-Lock® Grease Fitting Adapter

Connects any ⅛" NPTF male tube adapter directly to a standard grease fitting. Aluminum, carbon steel construction; fluorocarbons elastomer seal. Useful for connecting to drive-type fittings or metric fittings. Once installed, the Zerk-Lock cannot be removed from the fitting.

Part No.	Threads in. / mm	A in./mm	B in./mm	C in./mm
270784	⅛" NPSL Female	.625 / 15.9	.500 / 12.7	.500 / 12.7

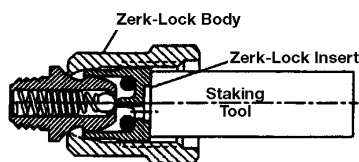

Installation Accessories



No. 247615 Staking Tool



Quicklinec® Fittings

Use for connections to 1/4" nylon tubing only. Can be used with Zerk-Lock® adapter or be screwed directly into bearing.

Part No.	Description
243699	1/4" tube x 1/8" NPT male 90° swivel fitting
244047	1/4" tube x 1/8" NPT male straight fitting
244048	1/4" tube x 1/8" NPT male 90° fitting
244053	1/4" tube x 1/4" -28 male 90° swivel fitting
244054	1/4" tube x 1/4" -28 male 90° fitting
244055	1/4" tube x 1/4" -28 male straight fitting
244058	1/4" tube x 1/4" tube splicer union



Divider Valve Outlet & Inlet Adapters for use with 272401 and 272394 Hose Stud

Part No.	Description
272658	Valve outlet fitting with check - 10mm
272659	1/8" NPT male straight fitting

IMPORTANT: Use the valve adapters for connecting the 1/8" high pressure hose (incl. hose stud with groove) to the main divider valve. The collet of the adapter is not knurled and has a wide collar.



Part No.	Description
432-24313-1	Protective Quicklinec rubber boot

Standard Compression Fittings

Part No.	Description
241290	1/4" tube x 1/8" NPT male straight fitting
241293	1/4" tube x 1/8" NPT male 90° fitting



Snap-On Connector Fittings

Part No.	Description
241388	90° snap-on connector for 1/4" O.D. tubing
241389	Straight snap-on connector for 1/4" O.D. tubing
66713	Compression nut for 241388 and 241389
82617	Straight snap-on connector for 1/8" O.D. tubing
82618	90° snap-on connector for 1/8" O.D. tubing
13112	Compression nut

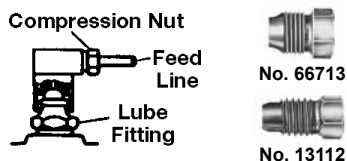

Tube Clamps for 1/4" O.D. Tubing

Part No.	A	B	C	No. of Tubes
64533-1	—	1/4" / 6.4	1/2" / 12.7	1
64533-2	15/16" / 23.8 mm	1/2" / 12.7	3/8" / 9.5	2
64533-3	13/16" / 30.2 mm	3/4" / 19.1	3/8" / 9.5	3
64533-4	17/16" / 36.5 mm	1" / 25.4	3/8" / 9.5	4
64533-5	111/16" / 42.9 mm	1 1/4" / 31.8	3/8" / 9.5	5

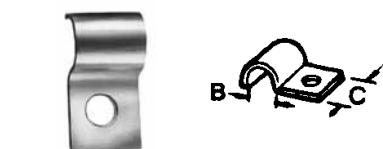

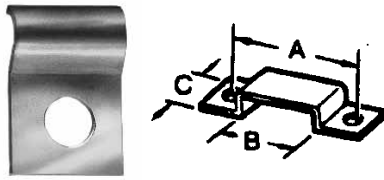

Tube Clamps for 1/8" O.D. Tubing

Part No.	A	B	C	No. of Tubes
64532-1	—	1/8" / 3.2	1/2" / 12.7	1
64532-2	1 1/16" / 17.5 mm	1/4" / 6.4	3/8" / 9.5	2
64532-3	1 3/16" / 20.6 mm	3/8" / 9.5	3/8" / 9.5	3
64532-4	1 5/16" / 23.8 mm	1/2" / 12.7	3/8" / 9.5	4
64532-5	1 1/16" / 27.0 mm	5/8" / 15.9	3/8" / 9.5	5

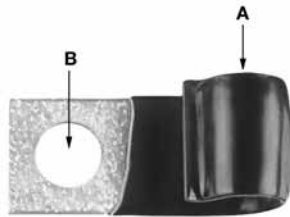

Insulated "J" Type Clamps

Part No.	A	B
68511	7/16" / 11.1 mm opening	1 3/32" / 10.3 dia. hole
68535	7/16" / 11.1 mm opening	1 7/32" / 13.5 dia. hole
68987	1 1/16" / 17.5 mm opening	7/16" / 11.1 dia. hole

Clip Screw



#6 Thd - 1/4" Long

No. 66202 for use in mounting 64532 and 64533 series tube clamps.



Spiral Wrap



Nylon Ties



Plastic Cap
242125

Bulk Supply and Feed Line Hose and Tubing

Part No.	Description
241110	Feed line bundling spiral wrap (10 ft. / 3 m length)
241120	Feed line bundling spiral wrap (20 feet/6m of spiral wrap)
241054	Nylon ties (100 count poly bag) 7" / 177.8 m length
241055	Nylon ties (50 count poly bag) 7" / 177.8 m length
241056	Nylon ties (25 count poly bag) 7" / 177.8 m length
242125	Plastic grease fitting cap
274097	20 feet/6m of 3/8" convoluted loom/split wrap
274098	20 feet/6m of 1/2" convoluted loom/split wrap
274099	20 feet/6m of 5/8" convoluted loom/split wrap



Convoluted Loom/Split Wrap

Lubrication Fittings & Accessories

Carton Quantities



Our popular fitting models are packaged in a convenient 100 piece carton for your small order requirements. Order a quantity of one and receive 100 pieces of that fitting.

1/8" NPT

100 Pc. Box No.	Bulk No.	Description	Length
5000C	5000	Straight	2 ¹ / ₃₂ "
5003C	5003	Straight	1 ¹ / ₄ "
5200C	5200	45° angle	7 ⁷ / ₈ "
5300C	5300	65° angle	2 ⁹ / ₃₂ "
5400C	5400	90° angle	2 ⁷ / ₃₂ "



1/4" NPT

100 Pc. Box No.	Bulk No.	Description	Length
5350C	5350	65° angle 1/4" NPT	1 ⁵ / ₃₂ "
5050C	5050	Str. 1/4" NPT	1 ⁵ / ₁₆ "

1/4"-28 SAE

100 Pc. Box No.	Bulk No.	Description	Length
5010C	5010	Straight-short thread	1/2"
5013C	5013	Straight-long thread	1 ¹ / ₁₆ "
5527C	5527	Straight-short thread	3 ¹ / ₆₄ "
5210C	5210	45° angle-short thread	7 ⁷ / ₈ "
5410C	5410	90° angle-short thread	2 ⁵ / ₃₂ "

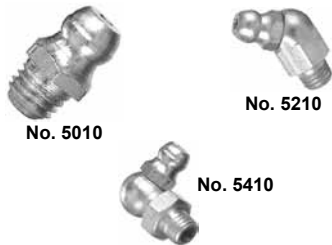

Metric

100 Pc. Box No.	Bulk No.	Description	Length
5175C	5175	Straight	6mm
5176C	5176	45°	6mm
5177C	5177	90°	6mm
5178C	5178	Straight	8mm
5179C	5179	45°	8mm
5180C	5180	90°	8mm
5181C	5181	Straight	10mm
5182C	5182	45°	10mm
5183C	5183	90°	10mm

Button Head

100 Pc. Box No.	Bulk No.	Description	Length
5701C	5701	1/8" NPT(m) thread	2 ⁵ / ₃₂ "
5706C	5706	1/4" NPT(m) thread	5 ³ / ₆₄ "



Drive-Type

100 Pc. Box No.	Bulk No.	Description	Length	Drive Dia.
5033C	5033	Straight	9 ⁹ / ₁₆ "	3 ³ / ₁₆ "
5385C	5385	65° angle	1 ³ / ₁₆ "	3 ³ / ₁₆ "
5031C	5031	Straight	3 ⁷ / ₆₄ "	5 ¹ / ₁₆ "



Lubrication Fittings & Accessories

Carton Quantities



Our standard bulk fittings are boxed in easy to handle cartons weighing approximately 30 pounds. The cartons are approximately 9"x9"x5". Order your fittings in these standard carton quantity increments to reduce your handling time.

Part No.	Standard Box Quantity	Part No.	Standard Box Quantity
5000	2500	5410-9	1500
5000-1	2500	5505	1000
5000-9	2500	5527	6000
5003	1200	5677	2700
5009	500	5678	2700
5010	5000	5679	2700
5010-9	5000	5680	2700
5013	4500	5698	1300
5014	3000	5701	1000
5031	3500	5706	800
5033	5500	5711	400
5033-9	5500	13154	1000
5036	2700	13155	750
5045	1500	20024	1300
5050	1000	20026	1300
5099	2500	20028	1000
5200	1500	20029	900
5210	2000	20031	1000
5300	1300	205000	2500
5308	1000	205010	5000
5318	2000	205200	1500
5350	700	205210	2000
5385	2200	205400	1300
5400	1300	205410	1500
5410	1500	240646	5000